

# ICULATE

## Portable Isolation Wards

*Solving for COVID-19, together*



# > CONTENT

1. Isolation wards
2. Categories and options
3. Comprehensive solution
4. Roll-out roadmap
5. Redeployment post-COVID
6. Our partners and credentials
7. Illustrative proposal

EOH



## ICULATE

A modular and rapidly deployable solution to expedite intensive and high care isolation ward facilities

The concept can either be an independent fully functional containerised solution, part of a larger temporary field hospital complex, or have the primary services retrofitted into existing under-specified hospital wards and non-traditional environments such as conference centres and community halls.

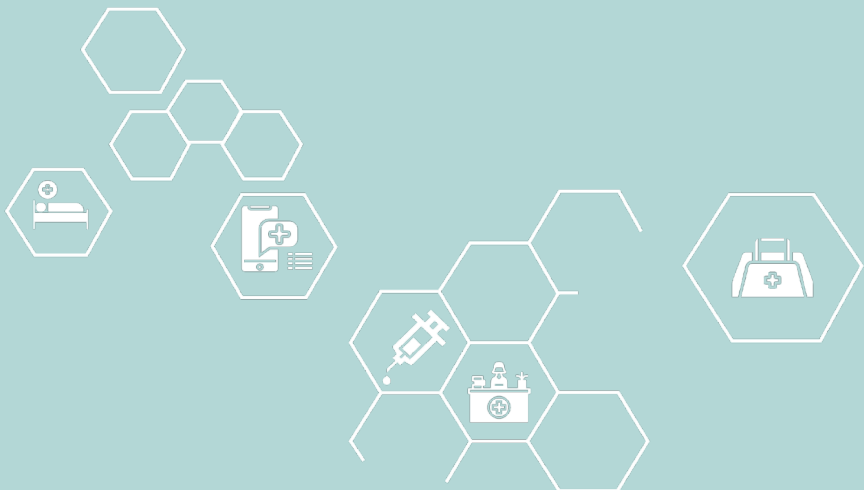

The Covid-19 pandemic has put a strain on healthcare systems throughout the world and based on international trends of the outbreak, South African hospitals will find it difficult to cope with the expected peak in a few weeks time, which creates the need to augment the healthcare system as a solution to dealing with the expected surge.

EOH's ICULATE solution is practically an ICU and Isolation ward in a box and includes for the complete spectrum of compliant infrastructure needed for both isolation wards and intensive care units, with the flexibility to easily downscale to accommodate either.

It is effectively a mobile medical ward that complies fully to international isolation ward and intensive care unit standards, that can be transported easily to any location within Southern Africa.

EOH specialises in crafting solutions for the sectors and industries it serves, and the healthcare sector in Africa is no different.

Our exposure to almost all facets of health infrastructure development and management has led to the development of the Hospital in a Box concept a few years ago, and now the

### ICUlate - ICU in a Box

aims to simplify and expedite the process of delivering ICU and isolation ward facilities throughout Africa that are robust, reliable, compliant and quick to assemble and commission.

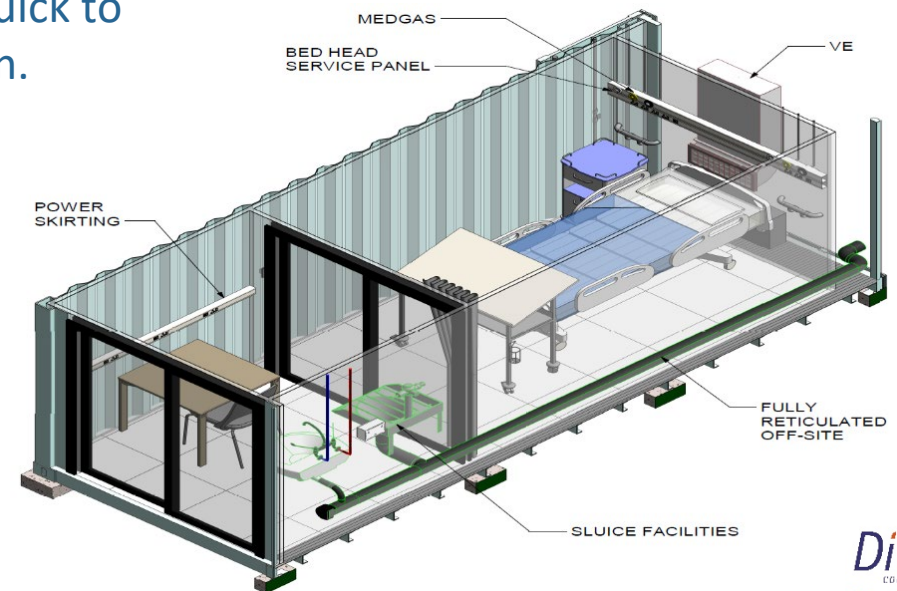

## ICULATE helps fight COVID-19

- **Portable, containerised** solution
- Complies with **international standards** for isolation ward and intensive care unit
- Specially designed **ventilation system** is effective against COVID-19 *and* similar diseases
- **Stand alone** or **retrofitted** into existing infrastructure
- Functional and **practical**
- Robust and **reliable**
- **Quick** and easy to build
- Operational and **maintenance friendly**



flexible and scalable



off-site manufacture  
reducing cost and time



fully fitted with hospital  
mechanical and electrical services



The healthcare design teams of EOH Dihlase and Osmond Lange Architects with collectively over a 200 years experience in hospital and communicable disease facility design, have taken on the challenge of designing a rapid mobilised intensive care/ isolation facilities that can standalone or be flexible enough to be included in any larger healthcare facility.

The design team has been engaging with specialist clinical teams from government and private sector relating to most appropriate design for Covid-19 pandemic facilities, taking most recent international policies into consideration. The clinical processes and configurations of these policies, in terms of infection prevention and control, have guided us to our concepts.

Depending on the possible built environment context for alternative care facilities for Covid-19 treatment there are a few options considered:

- The conversion of containers or prefabricated units into facilities for Covid-19 treatment (ICULATE)
- The adaption of existing clinical facilities to better suit Covid-19 treatment;
- The conversion of non-clinical departments in hospitals to accommodate Covid-19 treatment;
- The re-purposing of existing non-clinical facilities (schools, hotels etc) into Covid-19 treatment ready facilities

# 6 bed modular ICULATE Ward configuration

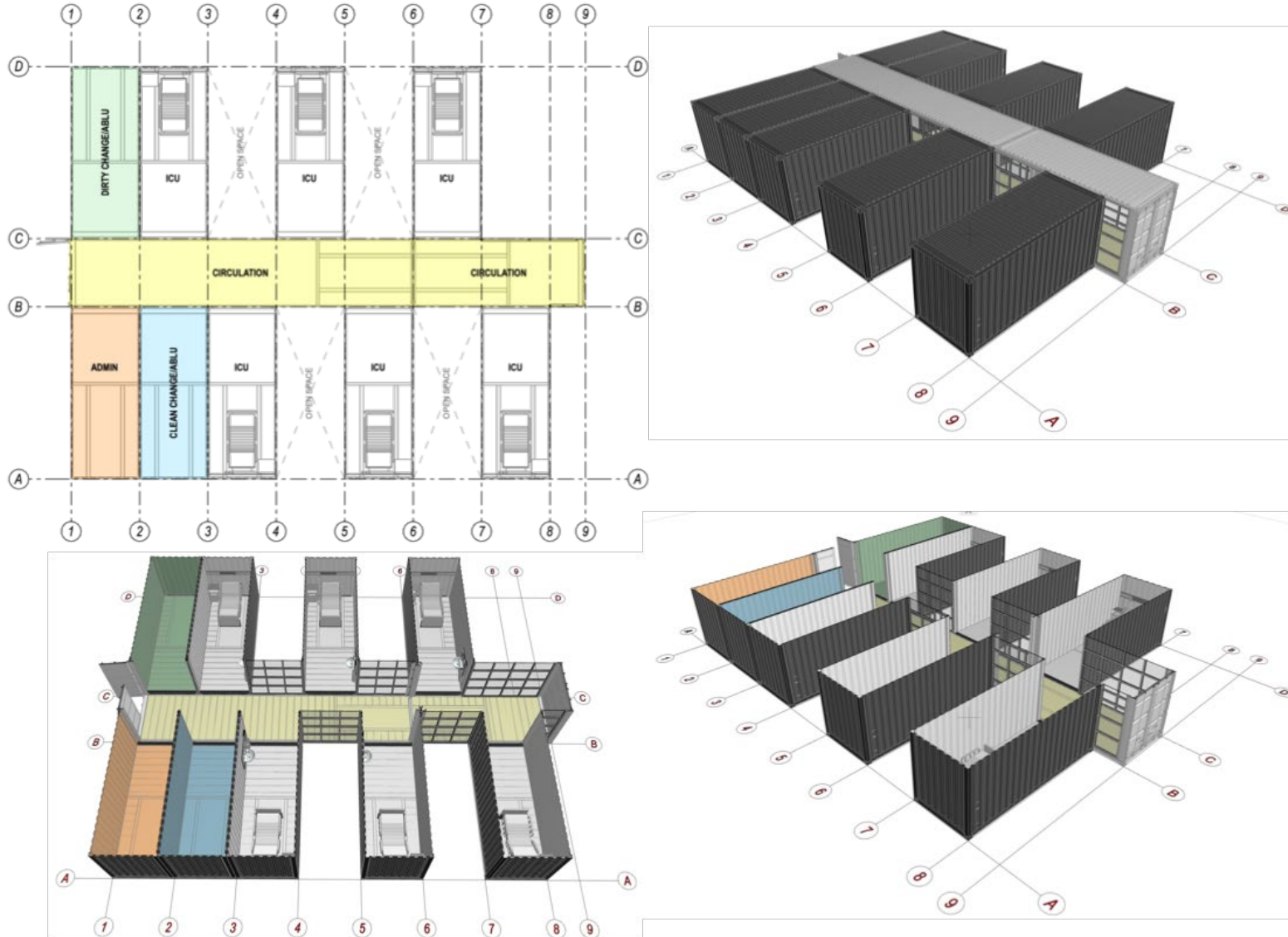

- These modules can be repeated to increase room numbers
- Colours are for illustrative purposes.
- A non-reflective external colour would be specified to reduce heat gain

# CATEGORIES and options





UNIVERSAL  
POD TYPES

INTAKE

ISOLATION

ICU

CONFIGURATION  
MODELS

INDIVIDUAL

MULTIPLE

DEPLOYMENT  
MODELS

TEMPORARY  
GREENFIELD  
SITES

RE-FIT EXISTING  
FACILITIES

ADD-ON  
CONTAINERS

SITUATION  
OPTIONS

RURAL

URBAN

## Another Illustrative Turnkey Isolation Ward Proposition covering Rural and Urban in a Province from South Africa's leading facilities infrastructure engineering consultancy

No	Units	Type	Urban/Rural	Wards	Beds / Ward	Roll-out Rate	Timing to Launch
1	Greenfields temporary structure site	Pre-fab or Container modules	Urban/Rural	Multiple	25 beds Ward	+ - 4 weeks per ward	From 2 weeks
2	Existing hospital ward conversion	Internal Fit out	Urban	Multiple	Multiple beds	From 1 week	From 2 days
3	Re-purposed hall conversion	Structure	Urban/Rural	Multiple	Multiple beds	From 1 week	From 2 days
4	Bolt-on external wards to existing facility	Pre-fab/Container modules	Urban	Multiple	25 beds Ward	+ - 4 weeks per ward	2 weeks

We have experienced programme management and engineering staff and capacity capable of rolling out multiple sites per week in urban and rural areas. Design and timelines are specific to client requirements. Final pricing subject to tender and specific solution required and designed for your application. Headline credentials – EOH / Dihlase are preferred engineers to the Dept of Health, Dept of Public Works and most of the private hospital groups. We are currently developing COVID facilities nationally on full turnkey basis

### Included

Planning and programme management  
Structures  
Power  
Nurses call  
Airconditioning, Ventilation, Nurses Call,  
Medical Gas, H&C water, drainage within facility  
Networks

### Optional

Furniture  
Ventilators  
Thermal screening  
Storage  
ICU options and equipment  
Wifi and Connectivity

# ➤ BENEFITS OF CONTAINERISED SOLUTION

## CONTAINERISED SOLUTION

- Can be re-used as a later stage as Outpatient facilities (NHI), Consulting rooms, Offices, Clinics, Community Centres, Laboratory Test Centres, etc
- Portable - A container can easily be moved from one location to another.
- Allows flexibility of use in terms of overall site layout  
Modification and fit out can occur off-site, prior to delivery to site, compliant to WHO suggested layouts
- Weather-proof system
- Can be incorporated with other systems to form a hybrid structure (eg prefabricated and membrane or metal sheeting systems for circulation; membrane systems for screening) including tower stacking.
- Container provides solid floor, ceiling and wall, ready for an infection resistant finish
- Container internal floor offers a substrate for a floor finish
- Pre modification and fit-out of containers means manufacturing under factory conditions and can be kept in stock and transported to required sites in the province at short notice superior strength and security.

# ➤ BENEFITS OF CONTAINERISED SOLUTION

- Affordable - No need to lay foundations or pay for months of construction work. The cost per square meter of a customised steel container is significantly lower than the cost of constructing a building from scratch.
- Strong and secure - Made from durable, weather-resistant steel, a converted container is designed to provide superior strength and security.
- Quick assembly and installation turn around time - A fully fitted container will take days from inception to final commissioning.
- Can be shipped anywhere in the world fully fitted with all services.



# ALTERNATIVE SYSTEMS COMPARISON

## TENT SYSTEM

- Vulnerable to the elements, including increased heat gain, and non-wind resistant
- Noise generation from the membrane under weather conditions would create undue and unpleasant noise affecting patient comfort and healthcare worker operations
- Will require a floor substrate prior to the floor finish
- Difficulty in pressurising a tented structure leading to infection control issues.
- Tented systems may also have textured surfaces, which could be an infection control risk when housing critically ill patients with compromised immunity
- Difficulty in suspending HVAC and other services;
- Partitioning would require support structure



# ALTERNATIVE SYSTEMS COMPARISON

## NEW BUILDING

- Expensive to construct
- Full professional team required
- Plan submission and approval process
- Extended time required for design and construction process. Need to lay foundations which has cost and time implications
- The cost per square meter of constructing a building from scratch is substantially higher than a customised steel container
- Cannot be easily be transported from one location to another.
- Much more labour intensive, which would not be in compliance with current lockdown restrictions.
- Construction industry is currently under lockdown, so there may be time and cost issues in mobilising a team.
- Availability of materials may also be a problem under lockdown.
- Rushed construction (weatherproofing issues)
- Left with a building that may not suit future use
- If expanding at a later stage, the cycle of the above points will repeat



The container modules can be linked and configured with other containers equipped with the medical ancillary services.

## RURAL OPTIONS

12m self-contained fully fitted ICULATE Isolation ward complete with integrated plantroom that can be easily transported to any site as a stand alone facility, soccer fields, etc.

12m or 6m self-contained fully fitted ICULATE Isolation ward that can be easily transported and connected to an existing clinic or interconnected to form a new emergency temporary facility (8 to 10 bed).

Retrofitting of ICULATE services into existing facilities such as rural schools, clinics, halls, etc.

➤ Stand-alone with no existing hospital facilities



Inside an empty, existing building like a school or hall



On an empty parcel of land like a sports field





The container modules can be linked and configured with other containers equipped with the medical ancillary services.

## URBAN OPTIONS

12m self-contained fully fitted ICULATE Isolation ward complete with integrated plantroom that can be easily transported to any site as a stand alone facility, e.g. empty parking lot, etc.

12m or 6m self-contained fully fitted ICULATE Isolation wards that can be easily transported and bolted-on to an existing hospital or medical facility or interconnected to form a larger temporary emergency facility (8 to 10 bed).

Retrofitting of the full suite of ICULATE services into existing rooms/wards in hospitals or in prefabricated emergency facilities within halls/conference centres, etc.



# ICULATE

The flagship 12m single container concept

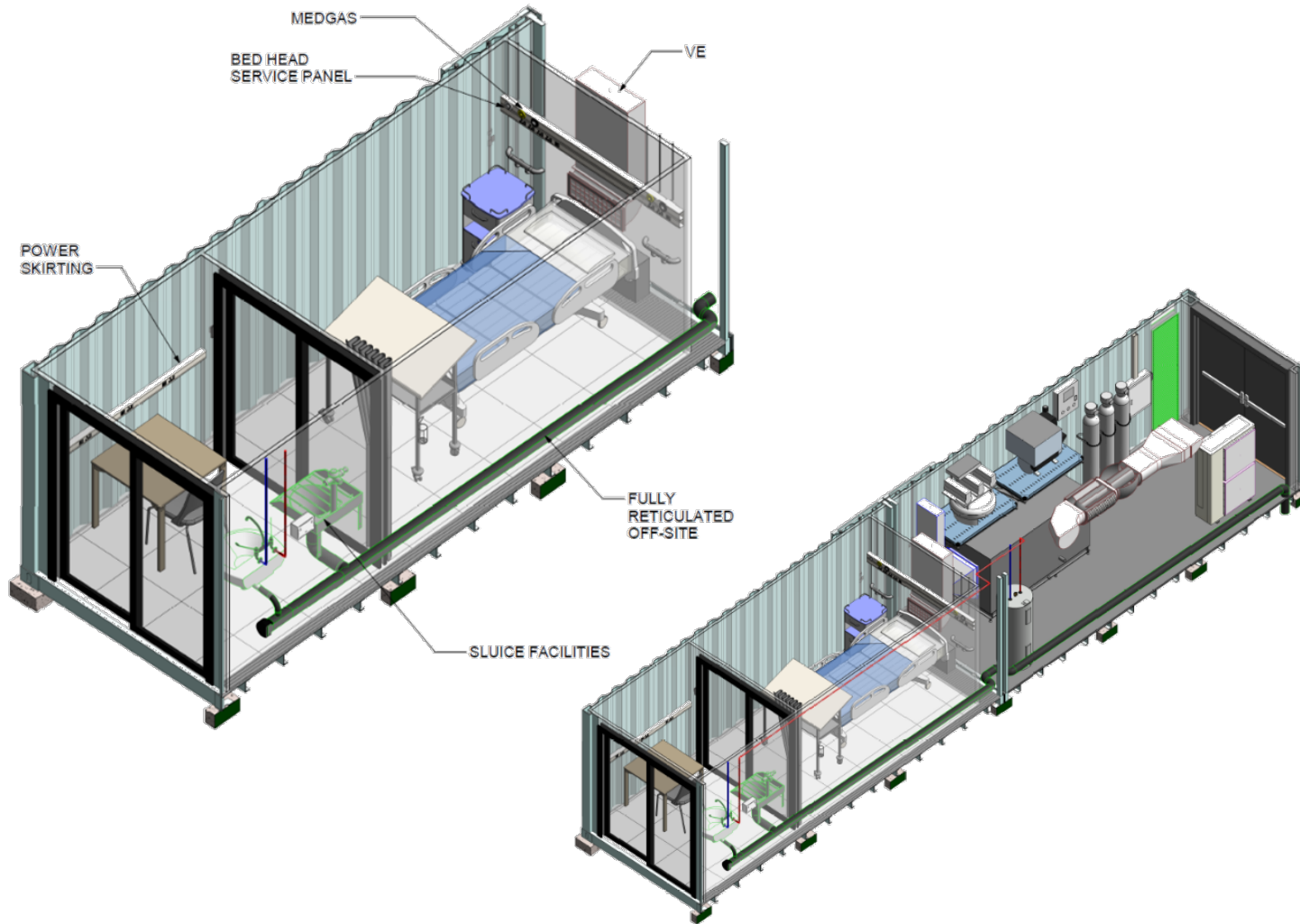



# > Cluster or bolt-on concept

12 or 6m containers positioned together to form an emergency field hospital facility, or bolted-on to existing facilities to increase hospital capacity

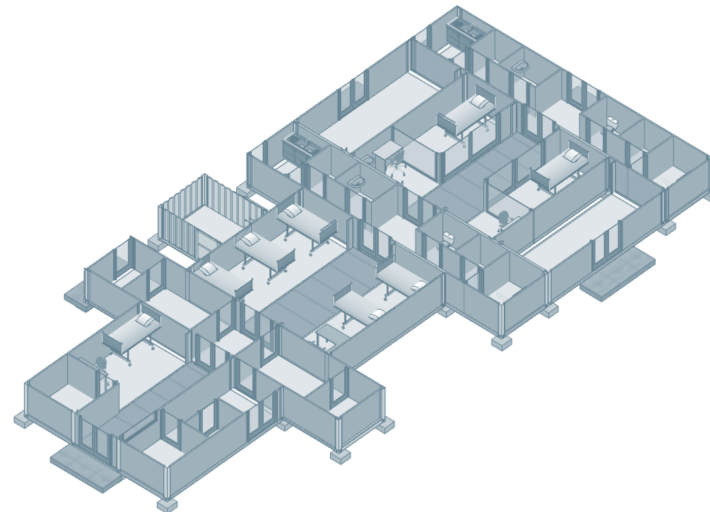
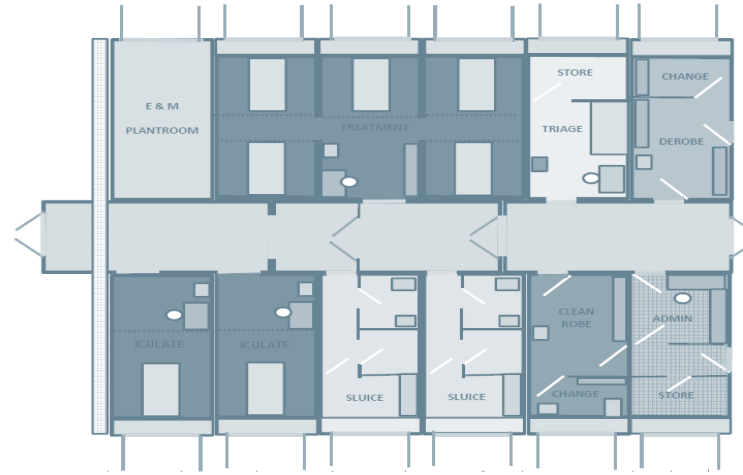

**Bolt-on/Cluster Hospital  
Concept  
to Existing Facility**

# 6 bed modular ICULATE Ward configuration

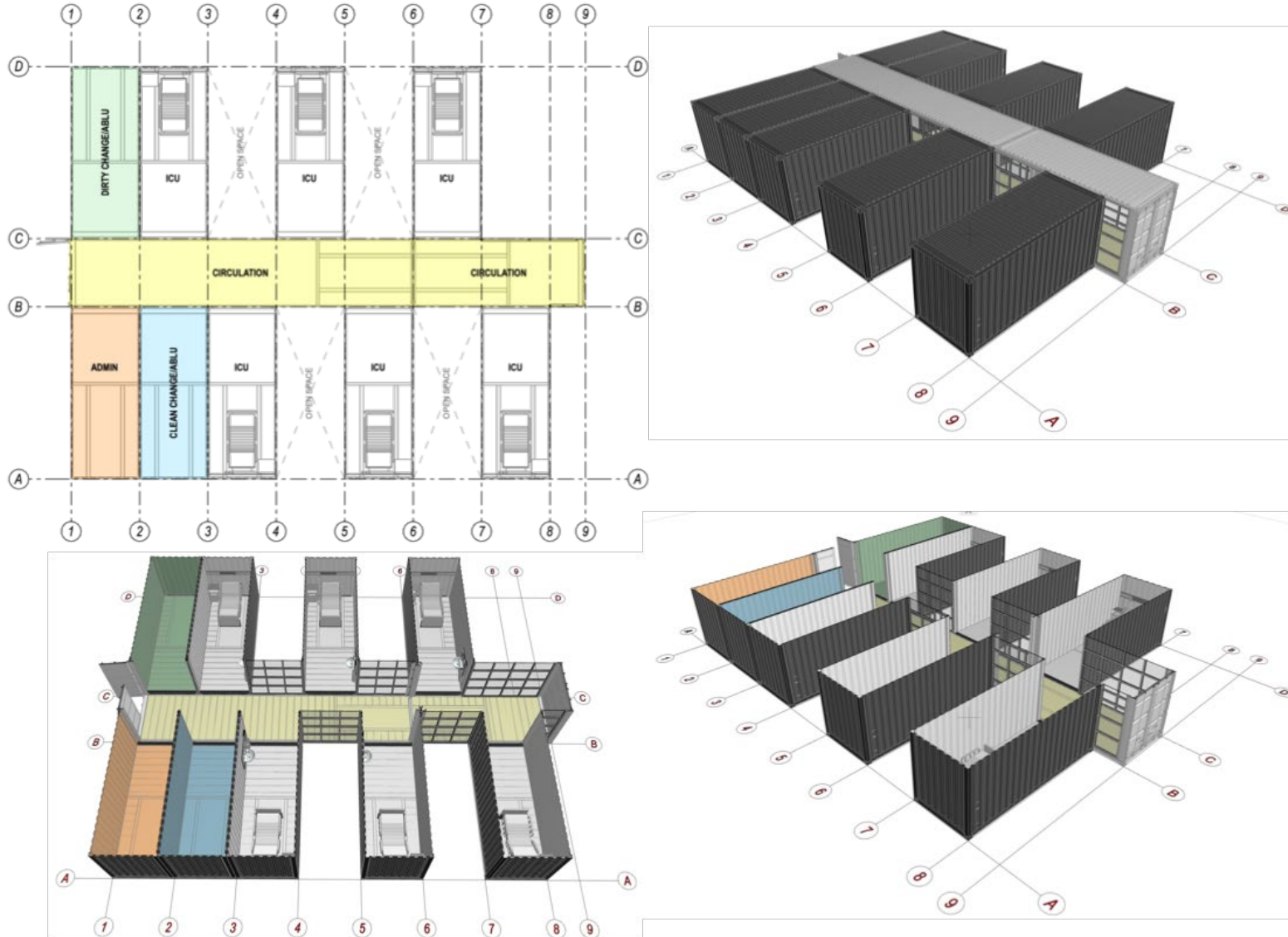

- These modules can be repeated to increase room numbers
- Colours are for illustrative purposes.
- A non-reflective external colour would be specified to reduce heat gain

# 12 bed modular ICULATE Ward configuration

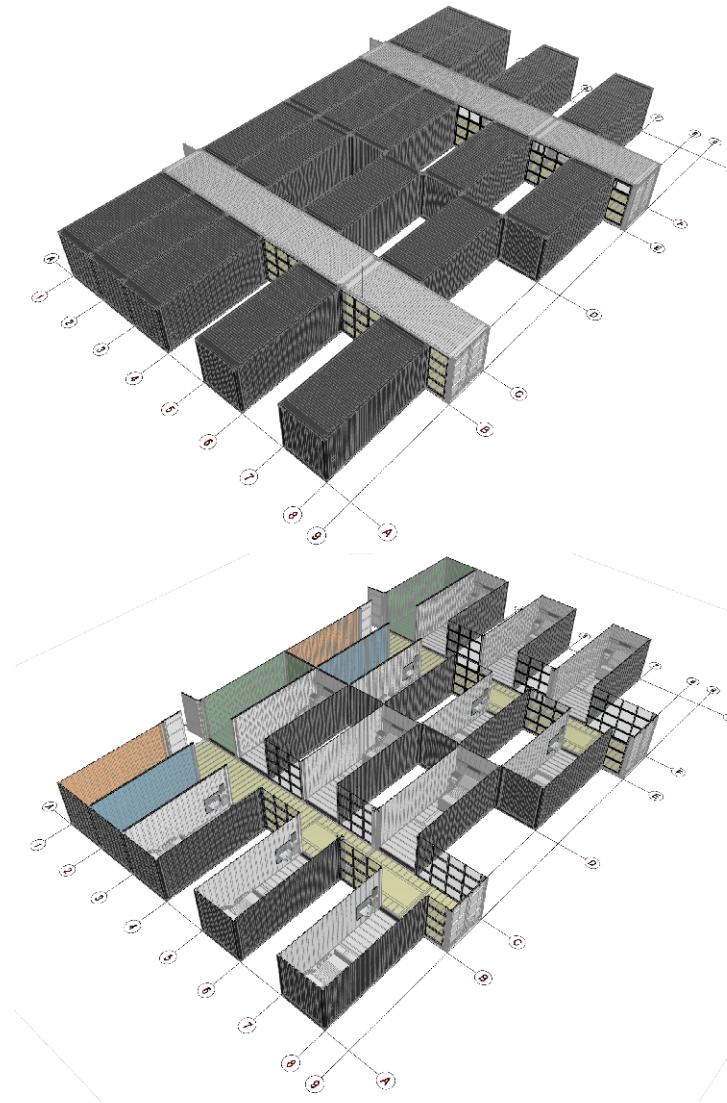
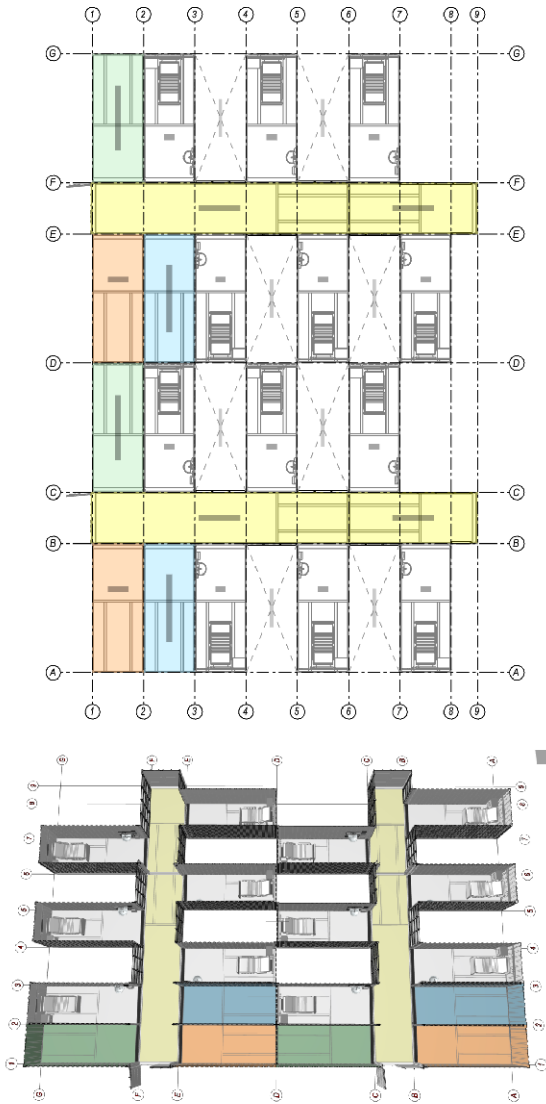

- Colours are for illustrative purposes.
- A non-reflective external colour would be specified to reduce heat gain

# 5 bed modular ICULATE Ward configuration

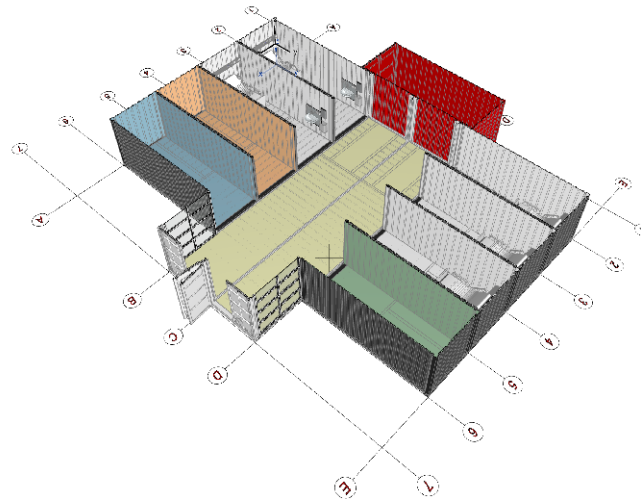
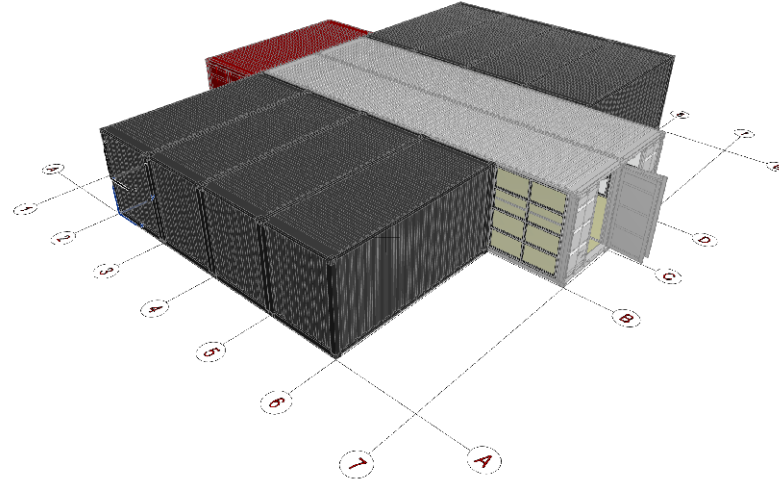
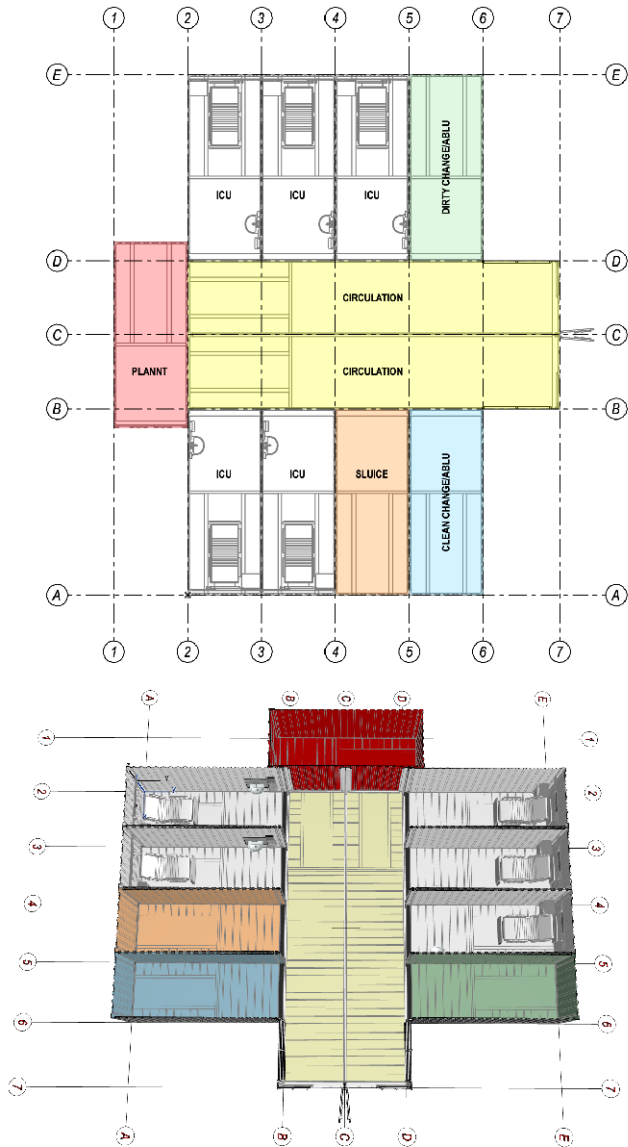

- Colours are for illustrative purposes.
- A non-reflective external colour would be specified to reduce heat gain

## Existing facility retrofit

Retrofitting of ICULATE services into existing facilities, medical or non-medical, complete with negative pressure, specialised exhaust ventilation system with HEPA (high efficiency particulate air filter) for air filtration before discharge and ante room. There is also an option of a (semi-ICULATE) 6m container housing electrical & mechanical (E&M) plant to be attached alongside the facility in a plug and play concept.

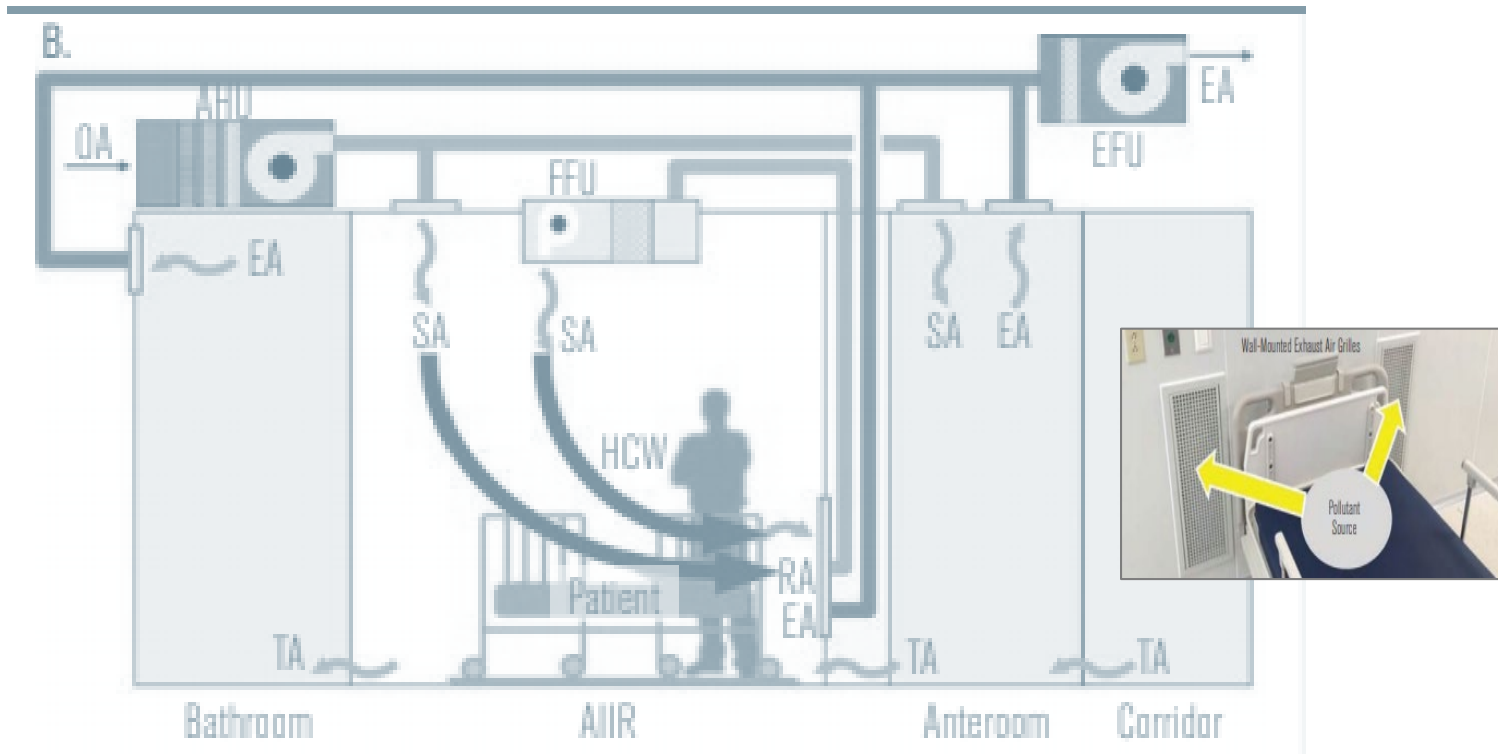



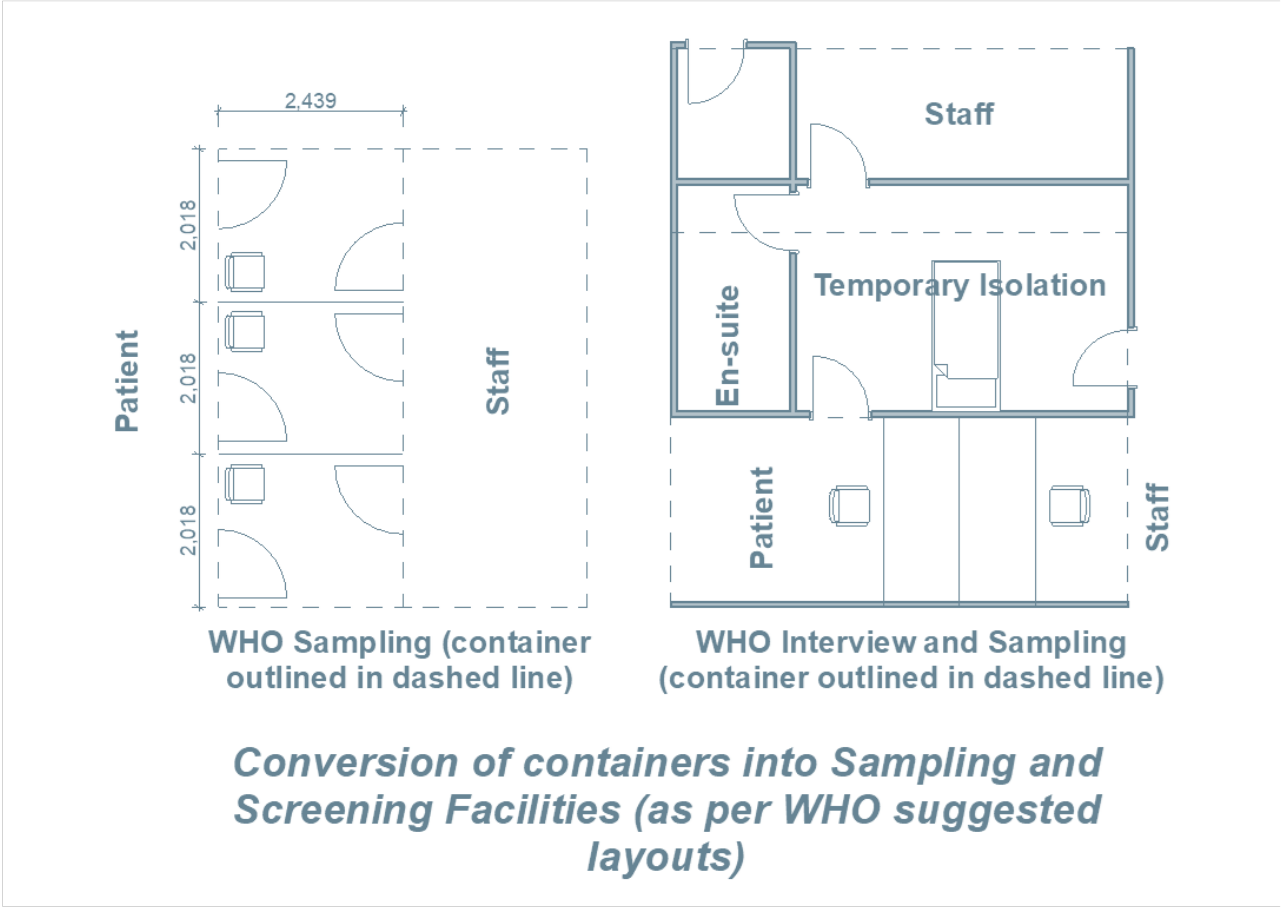

**ARCHITECT**  
Osmond Lange Architects and Planners (Pty) Ltd

Postal: PO Box 1621, Sandhurst, 2132  
Address: 3 Melrose Boulevard, Ground Floor, Melrose Arch  
E-mail: info@osmondlange.co.za  
Tel: +27 (0) 11 684 0020 / 0861 652 643  
Fax: +27 (0) 11 684 1436



## COMPREHENSIVE solution

Mechanical Systems  
Electrical & Electronic  
Fever detection services  
Medical systems architecture  
Security  
Communication networks  
Telephony and CRM



# MECHANICAL SYSTEMS

The electrical and mechanical installations will adhere to the relevant SANS regulations, Department of Health, IUSS and ASHRAE requirements.

- HVAC
- Medical Gas
- Hot & Cold Water
- BMS & Smart Systems

- Equipped with **specialised ventilation** and air conditioning system
- Ensures a **negative air pressure** in compliance with international standards
- Our specially designed ventilation strategies and HVAC controls are ensures that the airflow paths, induced supply air flow paths, and extraction grille placement are designed and coordinated to establish most effective **contaminant control**
- Locations of the SA and EA openings are the most important elements that directly affect the **pollutants dispersion** in the room, hence careful evaluation of the HVAC configuration can help in optimizing the flow path of air to obtain the desired combination of occupant thermal comfort and the best possible hygienic conditions in the ICULATE
- **On-board** water and medical gas systems



# Smart Options

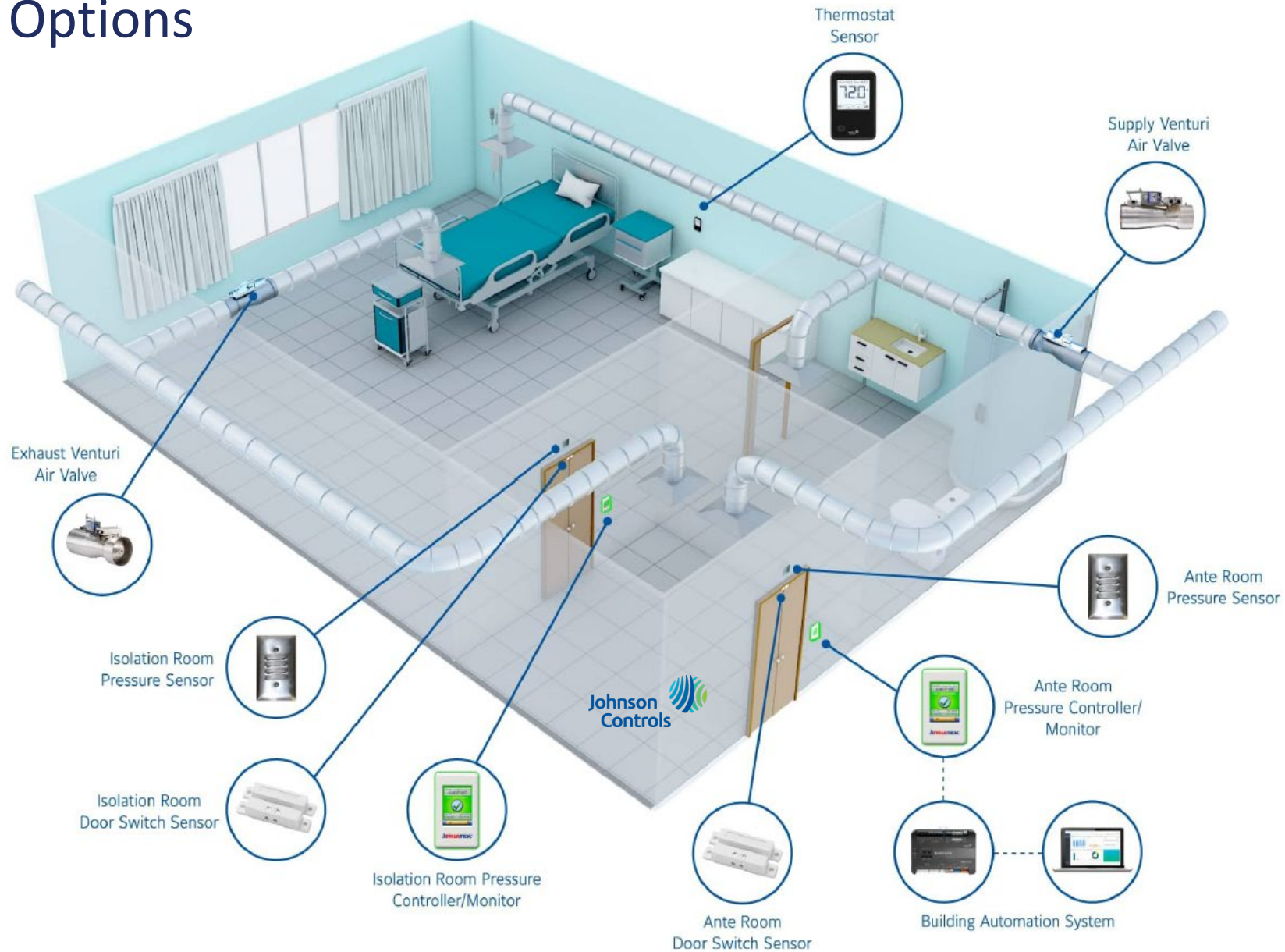

# Smart Options

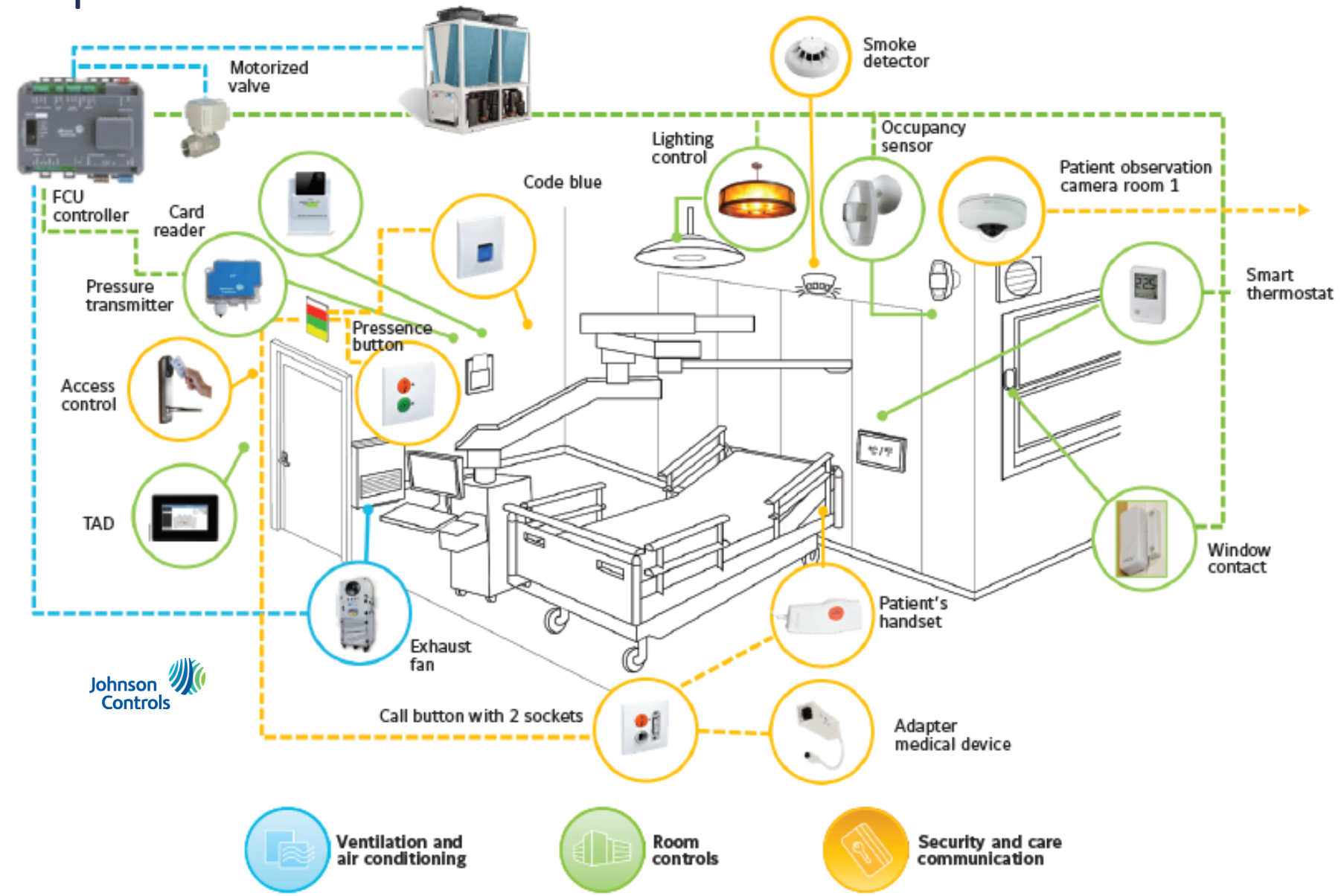

Ventilation and air conditioning



Room controls



Security and care communication



# ELECTRICAL SYSTEMS

The electrical and electronic design adheres to relevant SANS regulations, Department of Health specifications, and IUSS requirements.

- Power
- Lighting
- CCTV
- Access Control
- Nurses Call

- The electrical installation is designed in accordance with SANS regulations including SANS 10142 ensuring that the unit is wired and built up to **optimum operating and safe standards**.
- The unit will be equipped with a **specialised ventilation and air conditioning system** that ensures a negative air pressure and in compliance with international standards. It will also have an on-board water and medical gas system.
- The container will be equipped with a **panic button** installed which will send an alarm and light to the outside of the container so emergency medical staff can be notified should the patient needs urgent assistance. **Smart cameras** can also be utilised as an option for infection control and should there be a shortage of medical staff.
- The container **modules can be linked** and configured with other containers equipped with the medical ancillary services.

# ELECTRICAL SYSTEMS

- Supplied with power by use of a **generator** for use where limited power source available
- Generator will power a **UPS and small distribution board**
- Feed **3 major areas**:
  - Lights
  - Socket outlets on isolated supply for various medical machinery
  - Mechanical plant (air conditioning, hot water generation, medical gasses, etc.)
- Electrical installation in accordance with **SANS regulations**
  - SANS 10142 ensures the unit is wired and built to optimum operating and safe standards

# ELECTRONIC SYSTEMS

- CCTV
- Security
- Patient fever detection

- **Smart cameras** can also be utilised as an option for assisting in preventing infection control and patient monitoring should there be a shortage of medical staff
- Equipped with a **panic button** to send an alarm and light outside the container to alert medical staff should the patient need urgent assistance
- Equipped with a **panic button** to send an alarm and light outside the container to alert medical staff should the patient need urgent assistance
- **Smart cameras** can also be utilised as an option for infection control and should there be a shortage of medical staff
- **Thermal imaging cameras** can be used to detect Elevated Body Temperature. The **fever detection system** can scan 20 faces per second and allows non-invasive fever detection with no major disruptions to the flow of people in an area.

# > ELEVATED TEMPERATURE SCREENING

**Thermographic screening** can achieve an accurate level of Measurement in order to create an alarm in the event of an elevated body Surface Temperature Reading.

The display of temperature differences range from 0.1°C. Screening is via special TR windows or the complete sensor image with temperature range from -40 to 550°C. The temperature readings are non-invasive and non-contact (1.5 to 2.5m).

Screening of people entering premises is rapid (just over 2sec) and all screenings are recorded both in Thermal and Optical Spectrums to create an accurate record and audit.

**Accurately Measuring Temperature** is not just a case of point and shoot, understanding the Physics and Science behind the Technology is key to providing our clients with the correct technology and environment to achieve the required results which is what our solution is based on.

# TEMPERATURE SCREENING

## Skin temperature

Skin temperature is the temperature of the outermost surface of the body. Normal human skin temperature on the trunk of the body varies between 33.5 and 36.9 °C, though the skin's temperature is lower over protruding parts, like the nose, and higher over muscles and active organs. [Wikipedia](#)

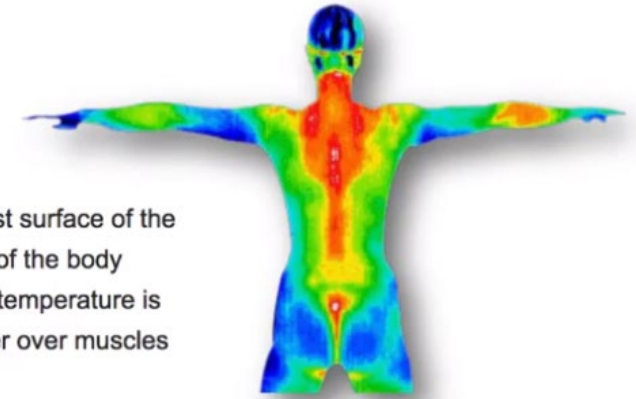

Temperature mapping between forehead and body under the environment temperature 25°C

Forehead Temperature (°C)	34.0	35.0	36.0	36.4	37.0	38.0
Core Body Temperature (°C)	36.0	36.8	37.5	37.8	38.3	39.1

Temperature mapping between forehead and body (°C)



Objects have different degrees of emission. Furthermore, radiation is reflected back from other objects. To increase the measuring accuracy, a black body radiator is therefore necessary, at best installed directly next to the object to be measured. This is the only way to ensure an exact reference value comparison. Distance and influencing environmental conditions must also be taken into account.



# TEMPERATURE SCREENING

- We utilise a Dual Spectrum (side by side Optical and Thermography Camera that offers a fiduciary image of the test subject/object)
- Built in Speaker and Microphone for remote two-way audio
- If a fully controlled test area is not possible, it would be suggested that each Measuring device be accompanied by a Black Body Radiator, conversely, with a controlled test area, a black body radiator will be used at time of set up for calibration and should be regularly be calibrated periodically thereafter (this is a service offered as part of a Maintenance/SLA)
- Should a high temperature be recorded, the person should be pointed towards a health official or approved designate that would need to conduct further tests and findings confirmed.

# MEDICAL SYSTEMS ARCHITECTURE

Bedhead Services

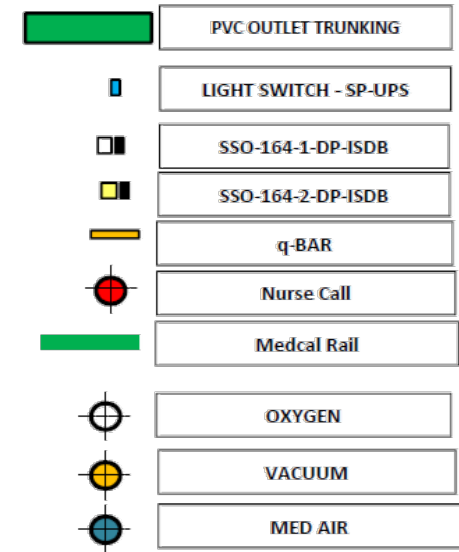
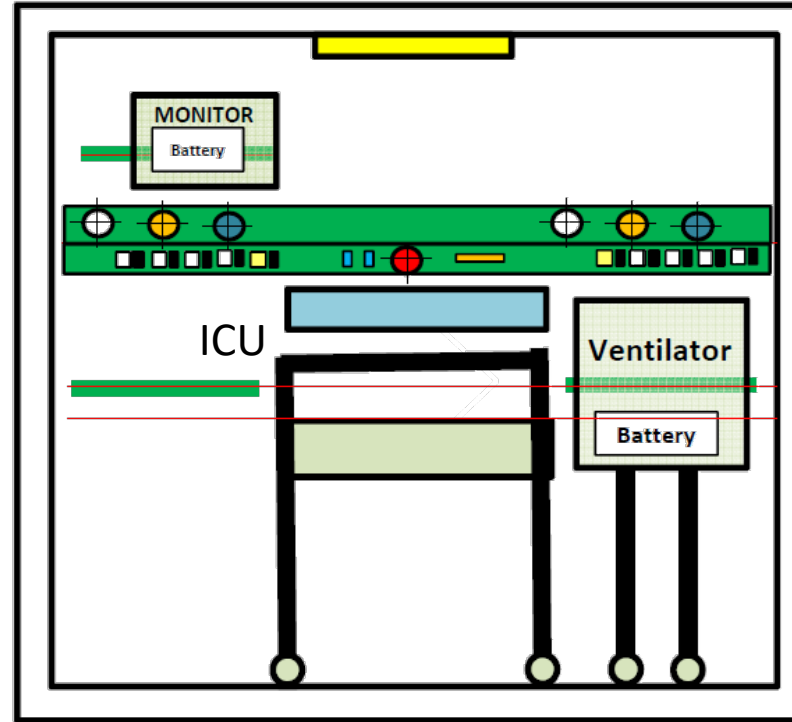

BROCHURE	SANS-10142	MEDICAL LOCATION GROUP	RECOMMENDED DEFINITION	ELECTRICAL SERVICES PERFORMANCE	ELECTRICAL OUTLETS RECOMMENDED	MEDICAL GAS OUTLETS RECOMMENDED
ICU Bed (Intensive Care Unit Bed)	INTENSIVE CARE UNIT	2	INTENSIVE CARE UNIT	UPS	8-SSO, q-BAR	2-OXY, 2-VAC, 2-MA
				ISOLATED SUPPLY ON GENERATOR	LIGHTING	
		1	ADVANCED TREATMENT BED (ATU)	NORMAL ON GENERATOR	8-SSO, q-BAR	2-OXY, 2-VAC, 2-MA
	ISOLATION UNIT	1	(Not provided)	NORMAL ON GENERATOR	6-SSO, q-BAR	NEGATIVE PRESSURE
ISOLATION BED		1	TREATMENT BED	NORMAL ON GENERATOR	6-SSO, q-BAR	AIR EXTRACT BEHIND PATIENT
					LIGHTING	1-OXY, 1-VAC, 1-MA

# COMMUNICATION NETWORKS

Rapidly deployable and expandable Wi-Fi solution for real-time information transfer of new virus infections and patient information

- Instant Wi-Fi coverage in areas where limited, unreliable or no Wi-Fi coverage exists
- Extending Wi-Fi coverage beyond existing access point installations
- Enhancing available data bandwidth (in conjunction with MNO service providers) to accommodate increased user data demand
- Eliminating 'dead-spots' within a defined, and/or extended operational area
- Enable remote monitoring of health care equipment
- Connect rapid deployed medical spaces
- Instantly connect temporary facilities to existing communication infrastructure

Connecting pop-up and mobile environments for emergency care

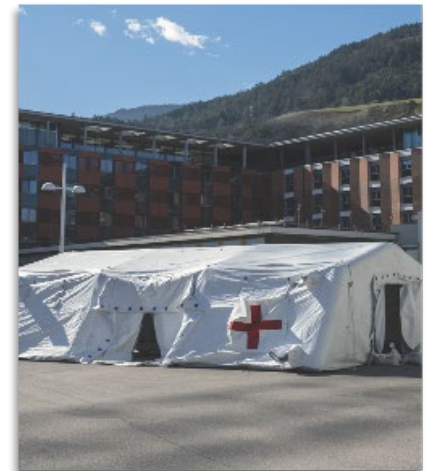

# COMMUNICATION NETWORKS

Critical communication for emergency medical spaces:

- Showgrounds
- Convention centres
- Vacated buildings
- Schools
- Recreation centres
- Stadiums
- Emergency medical tents
- Triage spaces



Kinetic Mesh scalable deployment

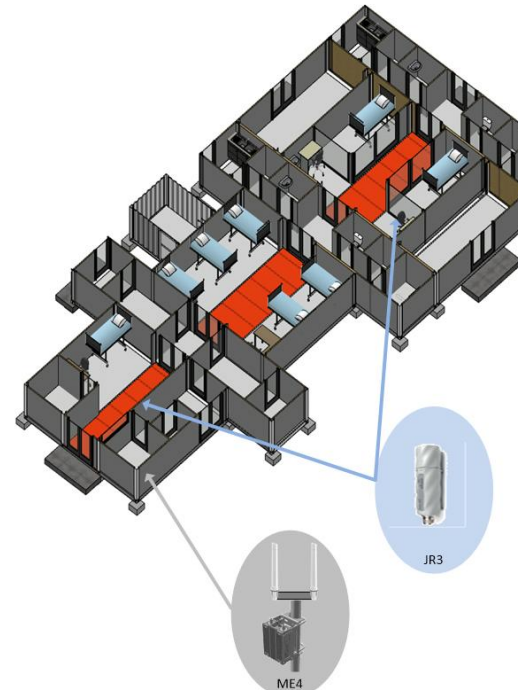

JR3 deployed for internal coverage

## Flexible deployment

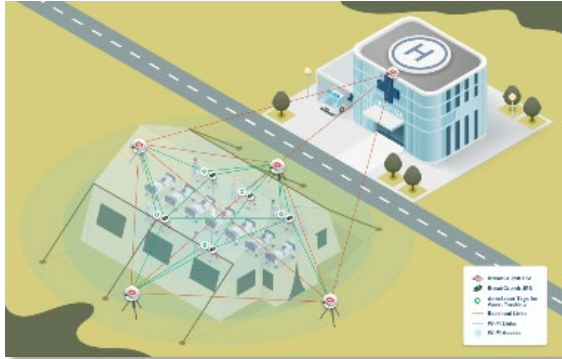

Adjacent to hospital

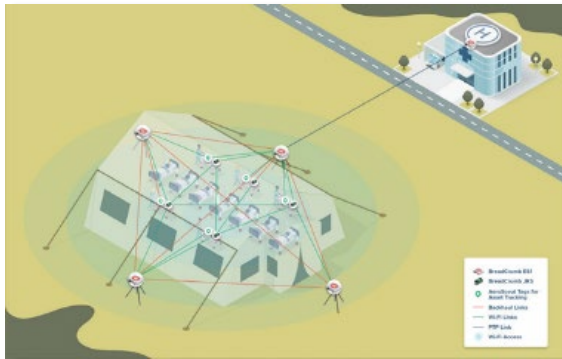

Long distance away  
with backhaul

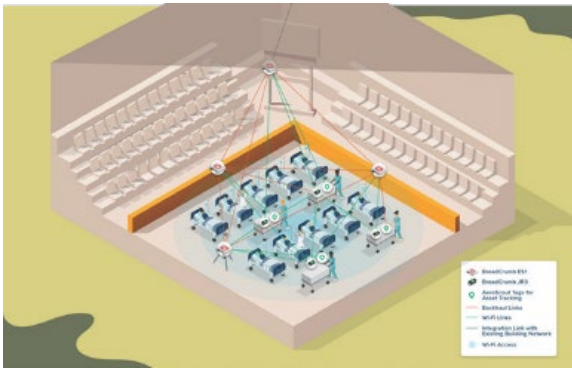

Stadiums

### Fast and simple deployment using BreadCrumbs

- Intelligent devices that manage their own routing where network coverage is needed
- It finds the fastest path back to the wired LAN
- Self-form a Layer 2 IP network so the network port on a BreadCrumb will work exactly like any network port in any room of your hospital
- Plug in a device and it will get an IP address and begin communicating



## > AIRBUS AGNET

Unique smartphone application that allows any number of smart devices (cell phones & tablets) to communicate and/or collaborate with each other regardless of their geographic location, at the touch of a single button.

- User communication may take the form of voice and/or data
- All participants are always on-line
- Multiple Emergency, Health Care, Security and Public Safety agencies can interact on a common communications platform
- Appointed administrators may identify the physical location a every group member
- All communication is secure and immune to interception
- All communication traffic is logged and time-stamped for future retrieval
- No need to carry multiple communication devices.
- Real time transfer to Covid-19 test data - with location and patient information



# Benefits

## **Gather**

- Smartphone users access secure communications groups and pass video, stills and other data both within their teams and to central command
- Groups can easily be created and new members added based on operational needs
- Groups with people using different devices seamlessly share images, maps, data and voice in real time

## **Process**

- Photos, videos, spoken communication and location data is transmitted by teams in the field.
- Central command helps tactical leaders have a more complete view and make better informed decisions
- Decision making is improved with additional information and streamlined by including the extended team directly
- Teams and resources are deployed with higher precision and more efficiency

## **Deploy**

- Team members know they are in the best position possible to achieve a successful outcome
- Unbroken visual and spoken communication between team members is maintained during the operation
- Changes in circumstances can be transmitted instantly in full detail for quick reassessment and rapid response

# CRM and TELEPHONE

## Custom Solutions

- Logistics management system
- Event management system
- OHS Risk Assessment solution
- Text message campaigns messaging portal

## Telephony Solution

- Accessed from anywhere with an internet connection
- Integrates with most softphones and most IP phones
- Scalable & reliable (used in over 90 countries)
- Smart routing and hunt groups
- Randomised or simultaneous phone ringing
- Outbound call restrictions
- CIRCLE
  - Comprehensive and feature rich app that keeps you connected
  - Integrates with your contacts
  - Make and receive calls using WIFI or mobile data connections
  - Create a favourites list
  - Realtime call recording

## CRM Solution

- Rapid rollout
- Custom query and quality assurance workflow
- Member/customer management
- Integrate with PBX, voice recordings, Email and SMS

# DEPLOYMENT models



# > DEPLOYMENT

Designed for quick assembly  
and rapid deployment

- The design is based on standard sized shipping containers to create **plug and play ward** units that can be quickly built and transported.
- Individual containers can be **interconnected via prefab panels** to create multiple modular configurations as per Client requirements.
- Placement of **overflow facilities** to extend care capacity safely and efficiently:
  - We have solutions to different scenarios and are working with public agencies and hospitals to answer critical emergency response questions.
  - The Department Of Health assessment following the lockdown was middle of July, but has now moved to September with the two week extension.
- This gives us just over **16 weeks** to prepare and be ready and organised to take on the full burden of the epidemic.



# ROLL-OUT PERIODS

## **12m self-contained fully fitted ICULATE Isolation ward**

### **Rollout Time: 10 days**

- Design Time 1 day
- Manufacture 7 days
- Delivery 1 day
- Erect and Commission 1 day

## **10 off 12m self-contained ICULATE pods within a new emergency hospital facility or bolt-on to existing hospital facility:**

### **Rollout Time: 30 days**

- Design Time 7 days
- Manufacture 14 days
- Delivery 2 days
- Erect and Commission 7 days

## **Retrofitting of ICULATE services into existing facilities**

### **Rollout Time: 10 days**

- Design Time 1 day
- Manufacture 5 days
- Delivery 1 days
- Erect and Commission 3 days

# POST-COVID 19 redeployment





## Redeploy the infrastructure

- Growing demand for medical facilities in remote and rural areas make the ICULATE the perfect solution, especially as it can easily be downscaled to a clinic or decommissioned and shipped out to other areas or even countries where it may be required once the outbreak fades off. This ensures redundant costs are offset by the flexibility of re-utilisation.
- The structure is quick to assemble and disassemble, and because it is made of shipping containers, it can be transported easily by road, rail and ship, within countries and from city to city around the world.
- The ICULATE encapsulates the healthcare services required for rapid disaster response and is designed to be robust and adaptable enough to be transported to any area where there is a need for any type of medical facility.

## > Redeploy the infrastructure, continued

- The solution can easily be downscaled to a clinic or decommissioned and shipped out to other areas or even countries where it may be required. This makes it the ideal solution as redundant costs are offset by the flexibility of re-utilisation.
- These temporary hospital spaces are more likely to support isolation and medical care for milder COVID-19 cases than to fully replicate a permanent hospital's ICU. But such modified hospital designs, as with the temporary hospital wards and field hospitals of past outbreaks, will likely be needed again for a second wave of outbreaks, and future possible epidemics.
- The solution will equip healthcare facilities with more flexibility for pandemics and other outlier events that create temporary surges in demand every five or 10 years.

## THE TEAM

### partners and credentials

- EOH Group
- Dihlase Consulting Engineers (Pty)Ltd
- Osmond Lange Architects (Pty)Ltd
- Johnson Controls International



## > Expert team

professional mechanical,  
electrical, and clinical hospital  
engineers

infection control  
specialists

ICT system  
engineers

software  
developers

asset  
management  
specialists

facility  
managers

> 100 YEARS  
experience







The EOH Group is the largest technology business in Africa, providing the technology, knowledge, skills and organisational ability critical to Africa's development and growth.

Following the Consulting, Technology and Outsourcing model, the EOH Group provides high-value, end-to-end solutions to its clients in all industry verticals. The Group employs more than 8 500 people, delivering technology solutions and knowledge services to over 5 000 large enterprise customers across all major industries. As a leader in driving and supporting digital innovation, the Group offers solutions along a simple Design- Build-Operate engagement model through its two independent businesses, EOH and NEXTEC.



Johnson Controls have been making buildings smarter since 1885. Their capabilities, depth of innovation experience, and global reach have been growing ever since. Today, they offer the world's largest portfolio of building products, technologies, software, and services; and put that portfolio to work to transform the environments where people live, work, learn and play from optimizing building performance to improving safety and enhancing comfort, we drive the outcomes that matter most. Dedicated to protecting the environment, we deliver our promise in industries such as healthcare, education, data centers, and manufacturing.



Dihlase Consulting Engineers is a professional consulting engineering company specializing in mechanical, electrical and ICT building services. Part of the EOH Group, Dihlase has

extensive experience in building infrastructure including specialist expertise in the healthcare and smart-precincts sectors. The company was established in 1948 , and has evolved over the years to become the leading consulting practice in the country being a preferred consultant to private and government healthcare sector. Their experience working closely with DOH infection control specialists in designing the communicable disease specialist hospitals hold them in good stead to assist with COVID-19 projects.



Osmond Lange Architects SA was established in 1929 and are one of the most reputable architectural practices in South Africa. They have substantial experience in the design of ICU and Isolation Facilities within complex healthcare projects, and their experience working with the DOH authors of the IUSS on the recent Lilian Ngoyi project has provided invaluable insight into IUSS thinking and deliverables in terms of infection prevention and control in the design of isolation facilities. Osmond Lange SA are capable and ready of successfully designing Covid -19 ready facilities as and Architect and Principle Agent.

# ILLUSTRATIVE proposal



# ILLUSTRATIVE COST PROPOSAL

## OPTION 1

12m self-contained fully fitted  
ICULATE Isolation ward

From R450,000 excluding Vat  
and delivery  
Price for design, manufacture,  
supply and install on site

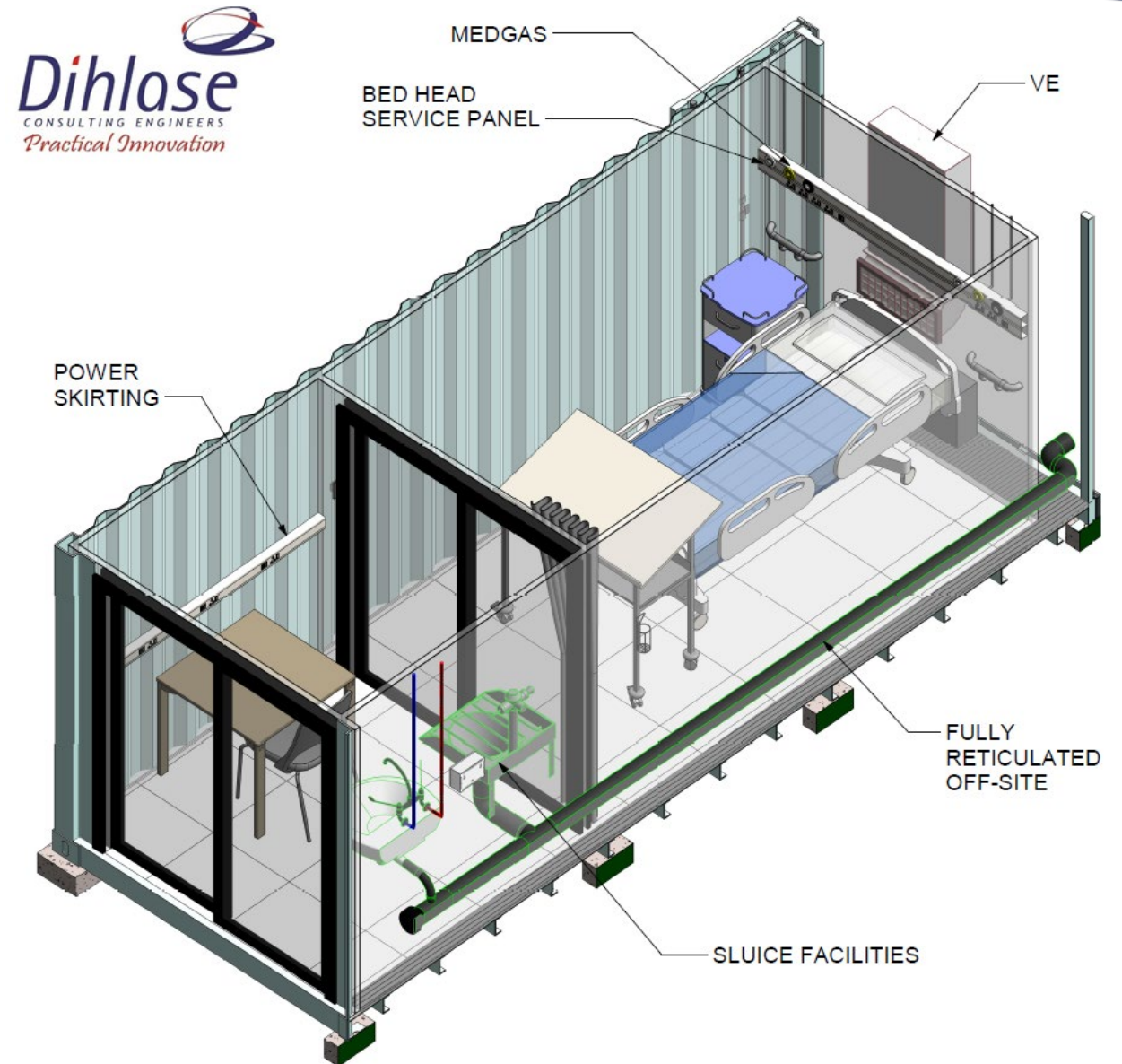

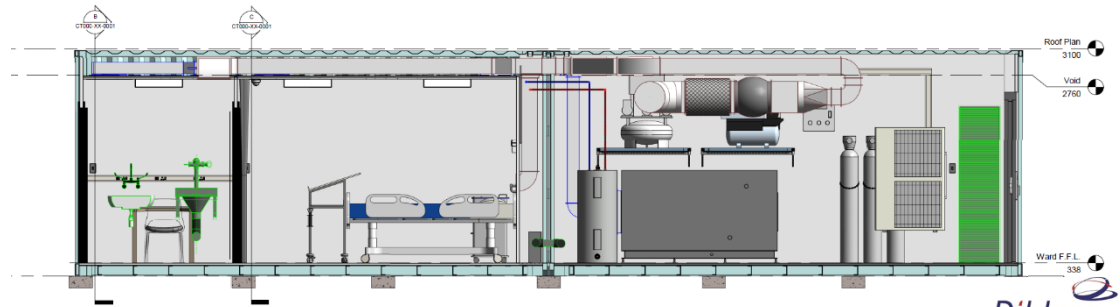
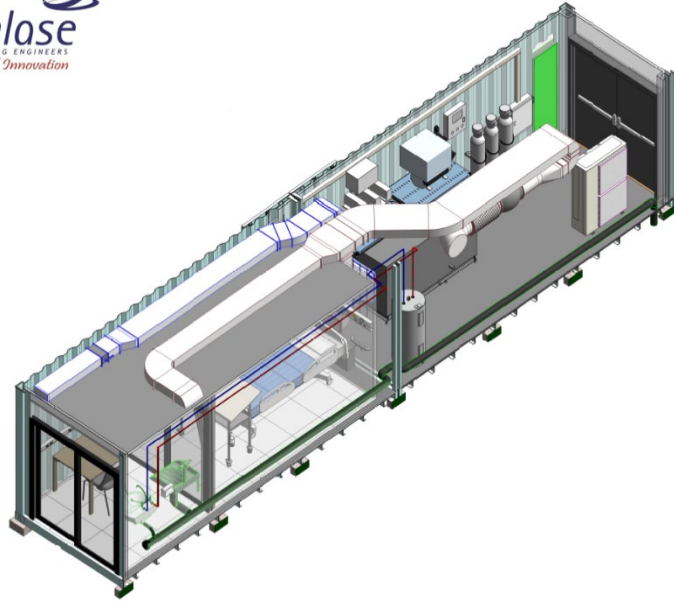

(A) Full Section  
1 : 25

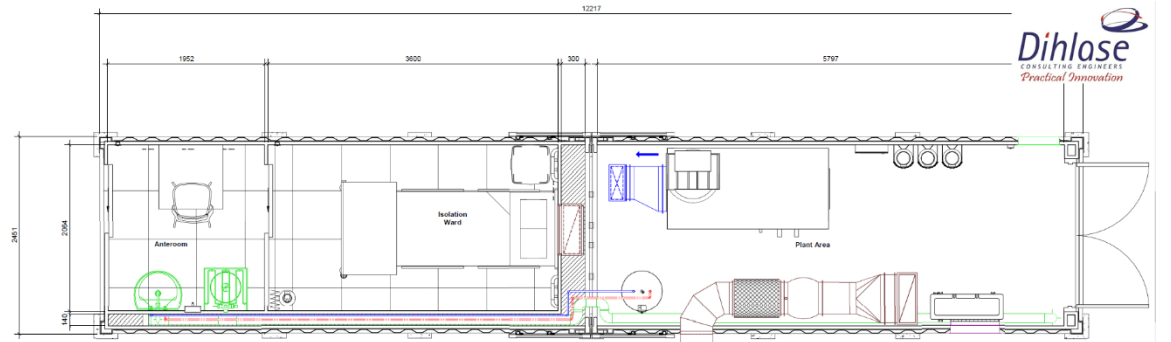
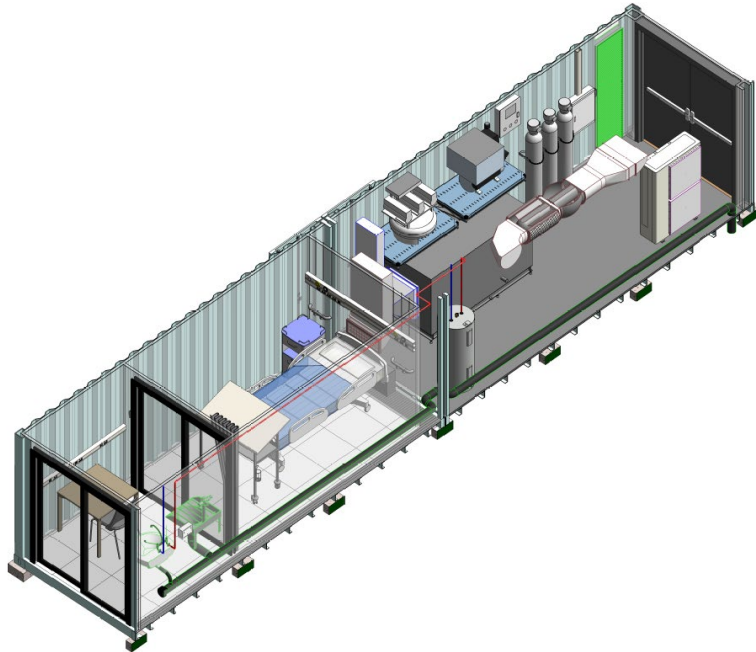

FLOOR PLAN  
SCALE 1:25

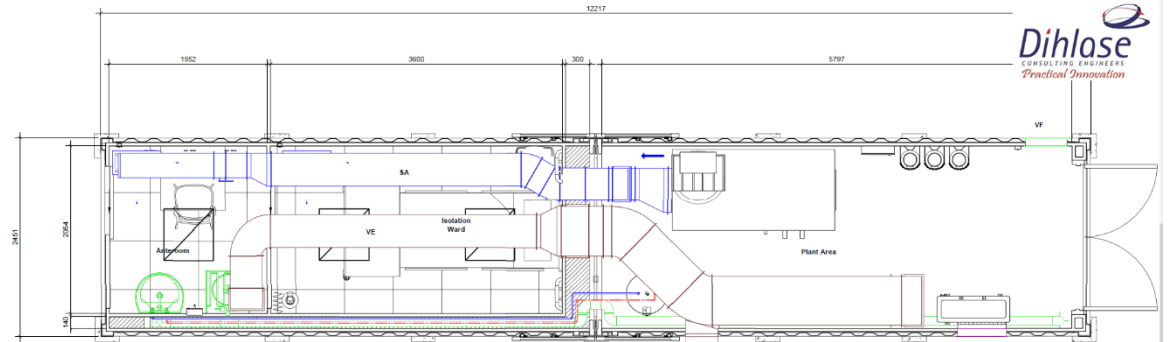

VOID SERVICES  
SCALE 1:25



## Another Illustrative Turnkey Isolation Ward Proposition covering Rural and Urban in a Province from South Africa's leading facilities infrastructure engineering consultancy

No	Units	Type	Urban/Rural	Wards	Beds / Ward	Roll-out Rate	Timing to Launch
1	Greenfields temporary structure site	Pre-fab or Container modules	Urban/Rural	Multiple	25 beds Ward	+ 4 weeks per ward	From 2 weeks
2	Existing hospital ward conversion	Internal Fit out	Urban	Multiple	Multiple beds	From 1 week	From 2 days
3	Re-purposed hall conversion	Structure	Urban/Rural	Multiple	Multiple beds	From 1 week	From 2 days
4	Bolt-on external wards to existing facility	Pre-fab/Container modules	Urban	Multiple	25 beds Ward	+ 4 weeks per ward	2 weeks

We have experienced programme management and engineering staff and capacity capable of rolling out multiple sites per week in urban and rural areas. Design and timelines are specific to client requirements. Final pricing subject to tender and specific solution required and designed for your application. Headline credentials – EOH / Dihlase are preferred engineers to the Dept of Health, Dept of Public Works and most of the private hospital groups. We are currently developing COVID facilities nationally on full turnkey basis.

### Included

Planning and programme management  
Structures  
Power  
Airconditioning, Ventilation, Nurses Call,  
Medical Gas, H&C water, drainage within facility  
Networks

### Optional

Furniture  
Ventilators  
Thermal screening  
Storage  
ICU options and equipment  
Wifi and Connectivity

# ILLUSTRATIVE COST PROPOSAL

## OPTION 2

2 to 12 off 12m self-contained ICULATE within a new emergency hospital facility or bolt-on to existing facility.

From R950,000 excluding Vat and delivery  
Price for design, manufacture, supply and install on site

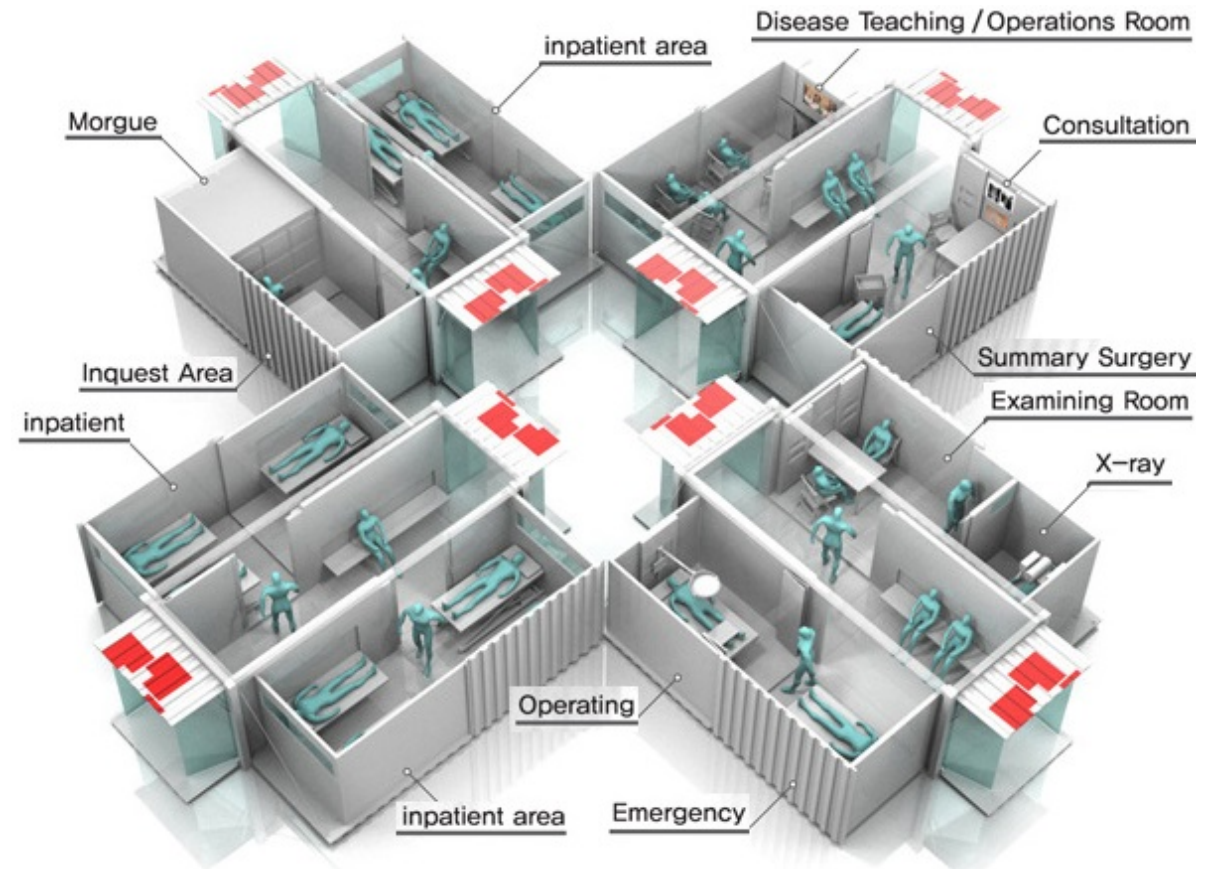

Conceptual 12 container design



# ILLUSTRATIVE COST PROPOSAL

## OPTION 3

Retrofitting of ICULATE services into existing facilities

From R125,000 (single private ward) excluding Vat and delivery  
Price for design, manufacture, supply and install on site

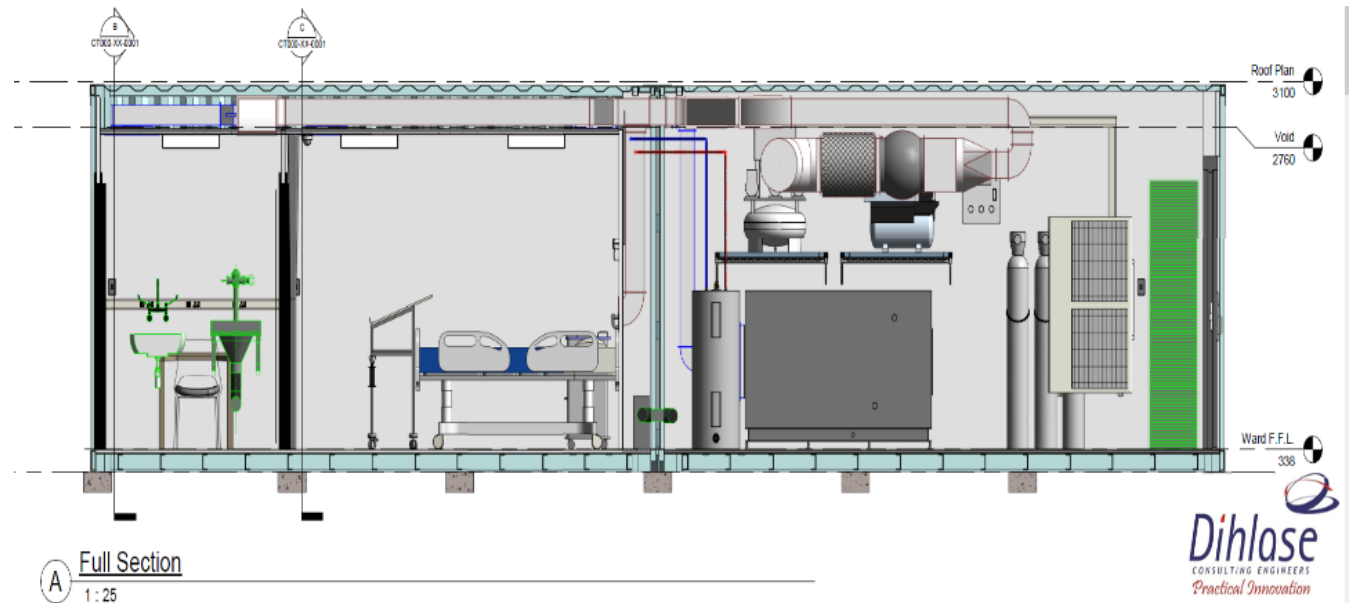
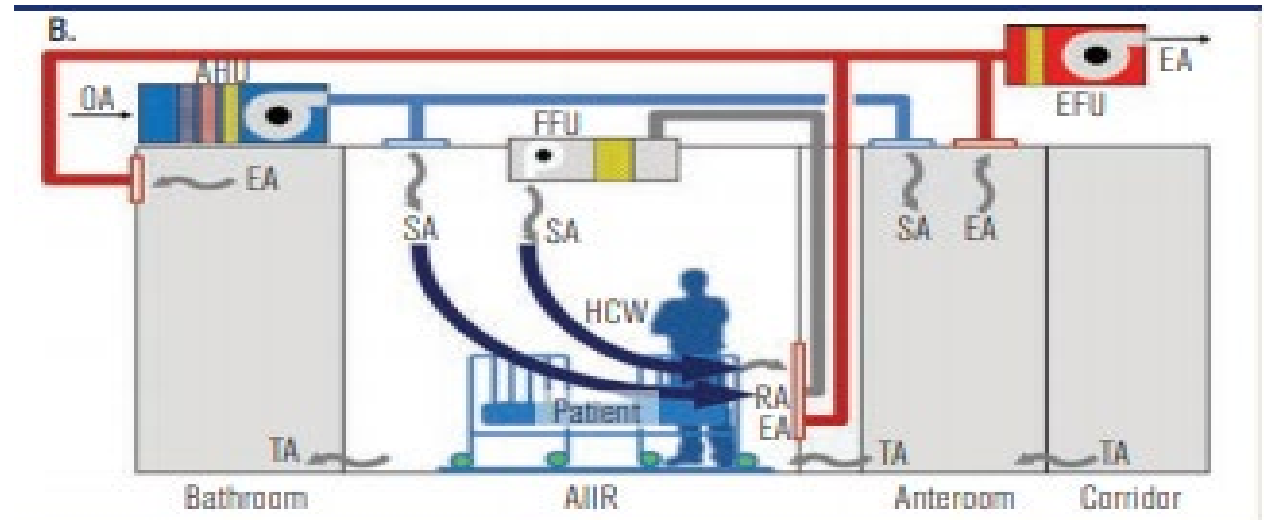

# ILLUSTRATIVE COST PROPOSAL

## Optional Extras Rajant (Kinetic Wi-fi Mesh)

Description	Single 10-Bed Isolation Unit	Multiple (10x) 10-Bed Isolation Units
Aggregation Mesh Unit(s)	R194,020	R391,855
Kinetic Mesh Unit(s)	R136,615	R1,366,100
Indoor Wi-Fi Mesh Unit(s)	R74,025	R740,180
PTP Backhaul Link(s)	R84,320	R168,624
Preliminary and General	R127,900	R596,500

### Terms and Conditions:

- Estimates based on preliminary concepts and assumptions
- Prices exclude VAT
- Excludes Deployment Services (labour, travel, accommodation, meals etc.)
- Excludes Internet Access and User Data Costs
- Final pricing subject to engineering and design scope definition

# ILLUSTRATIVE COST PROPOSAL

## Optional Extras

Airbus Agnet 'Crisis  
Commander' Subscriptions

Description	Monthly Subscription	Unit of Measure
Field User License (Smartphone)	Euro 10 (ZAR 220)	Per Device
Desktop Despatcher	Euro 16 (ZAR 340)	Per Desktop Station

### Terms and Conditions:

- Estimates based on preliminary concepts and assumptions
- Prices exclude VAT
- Excludes Deployment Services (labour, travel, accommodation, meals etc.)
- Excludes Internet Access and User Data Costs
- Final pricing subject to engineering and design scope definition

# FURNITURE & EQUIPMENT

We are able to supply a range of innovative low cost furniture and equipment options based on your requirements.

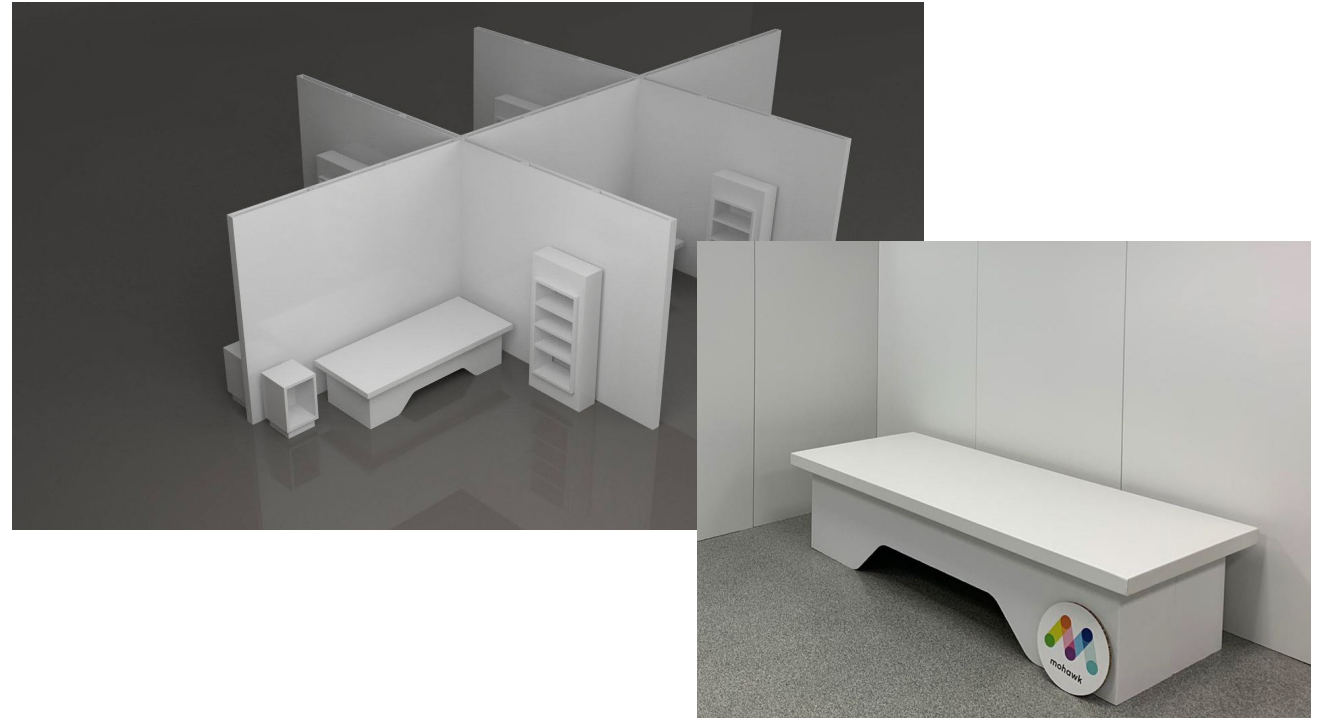

# Contact us

**Mohammed Rawat**

Regional Director

Dihlase, an EOH company

cell: +27 (82) 417 8644

[mohammedr@dihlase.co.za](mailto:mohammedr@dihlase.co.za)

**Milton Streak**

EOH Divisional Executive

cell: +27 (83) 6010578

[milton.streak@eoh.com](mailto:milton.streak@eoh.com)

